

Flat Rolling Equipment & Engineering Services

Quad flat rolling services include engineering / feasibility studies, process engineering services, research and development, equipment design and supply.

- Engineering / feasibility studies including:
 - Layout development
 - Process selection
 - Capacity / production calculation
 - Equipment selection, sizing and specification
 - Budget estimation
- Process engineering services including:
 - Strip shape simulation and control
 - Local shape defects simulation and reduction
 - Drive train non-linear dynamic simulation (TAF calculation)
 - Coil flow discrete event simulation and productivity calculation
 - Tension leveling process simulation
 - Mathematical Models for Mill Setup and Control
 - Computerized pass schedule design program & schedule optimization for cold reduction mills, temper mills, plate mills, and hot strip mills
 - Mill equipment failure and reliability analysis, FEA analysis, design optimization based on FEA
 - Thermal and cooling process analysis
 - Suitability analysis of used equipment



Quad flat rolling simulation software

Maximum Shear Stress
MPa
Max: 2.520e+002
Min: 1.190e+000
2006/6/29 16:46

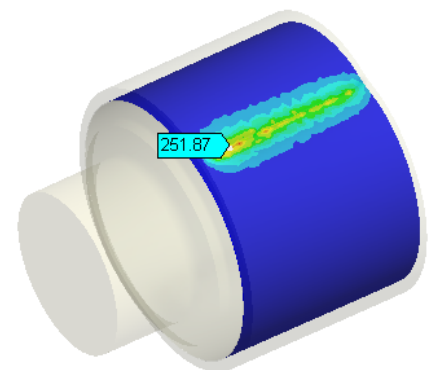
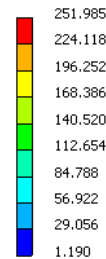

Composite roll failure analysis

Flat Rolling Equipment & Engineering Services

- Research and development including:
 - Local shape defects simulation and control
 - Ridge buckle reduction technology and equipment
 - 3D coiling process simulation
 - Shape and profile simulation for hot strip rolling process
 - Leveling process modeling
 - Rolling mill dynamic analysis
 - Rolling mill thrust loading analysis
 - Titanium rolling process development
- Equipment design and supply
 - Quad has designed and supplied many new and upgraded equipment, especially non standard custom designed equipment

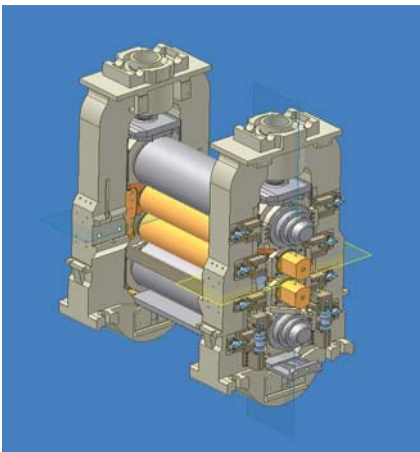

160" plate mill retrofit – Housing, chocks & Quick roll change system

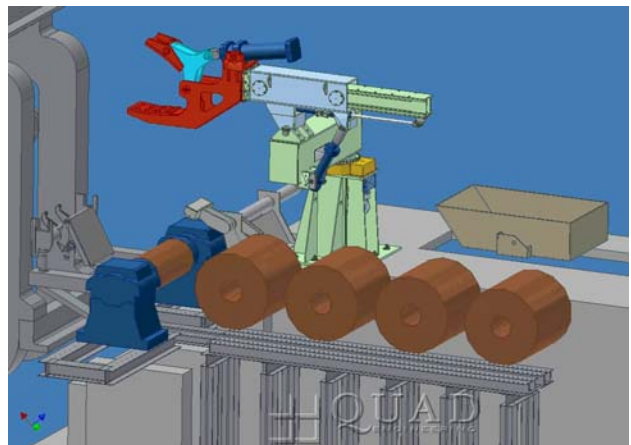

Custom designed pup coil removal system to increase productivity and safety